



**PRESSURE SWITCHES
PRESSURE DIFFERENCE SWITCHES
VACUUM SWITCHES**
From 1.5 mbar to 600 bar

MT High Proof High Range Pressure Switches

C A T A L O G U E

Certificate No.: FM72815



Kaustubha Udyog AN ISO9001:2008 COMPANY

S. No. 36/1/1, Sinhgad Road, Vadgaon Khurd,
Near Lokmat Press, Pune 411 041 INDIA
Tel. : +91-(0) 20-24393577 / 24393877
Telefax : +91-(0) 20-24393577 / 25460486
Email : pressure@vsnl.com

Website : <http://www.orion-instruments.com>

PRESSURE CAPSULE DETAILS

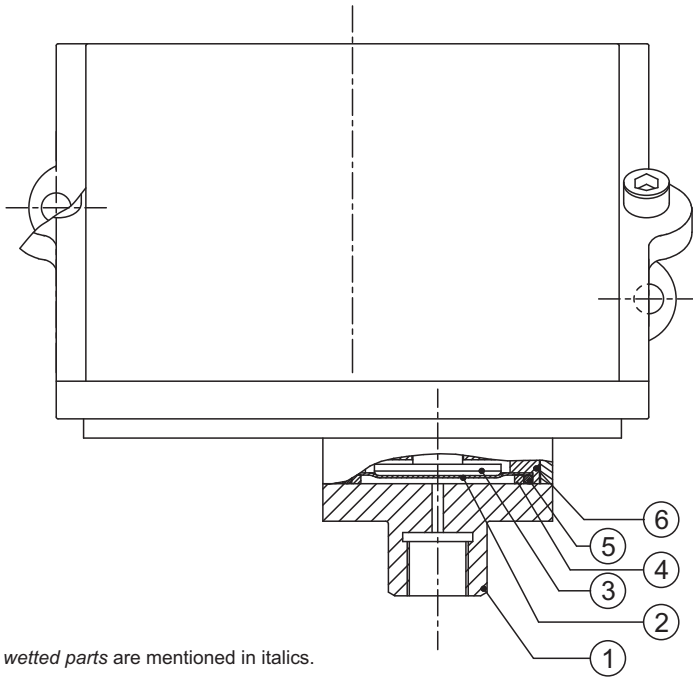

No. Description

1. *Pressure port (SS316)*
2. *Diaphragm (Teflon)*
3. *Plunger*
4. *Steel ring (SS316)*
5. *O-ring (Teflon)*
6. *Disc*

Note : *wetted parts* are mentioned in italics.

INSTALLATION DRAWING

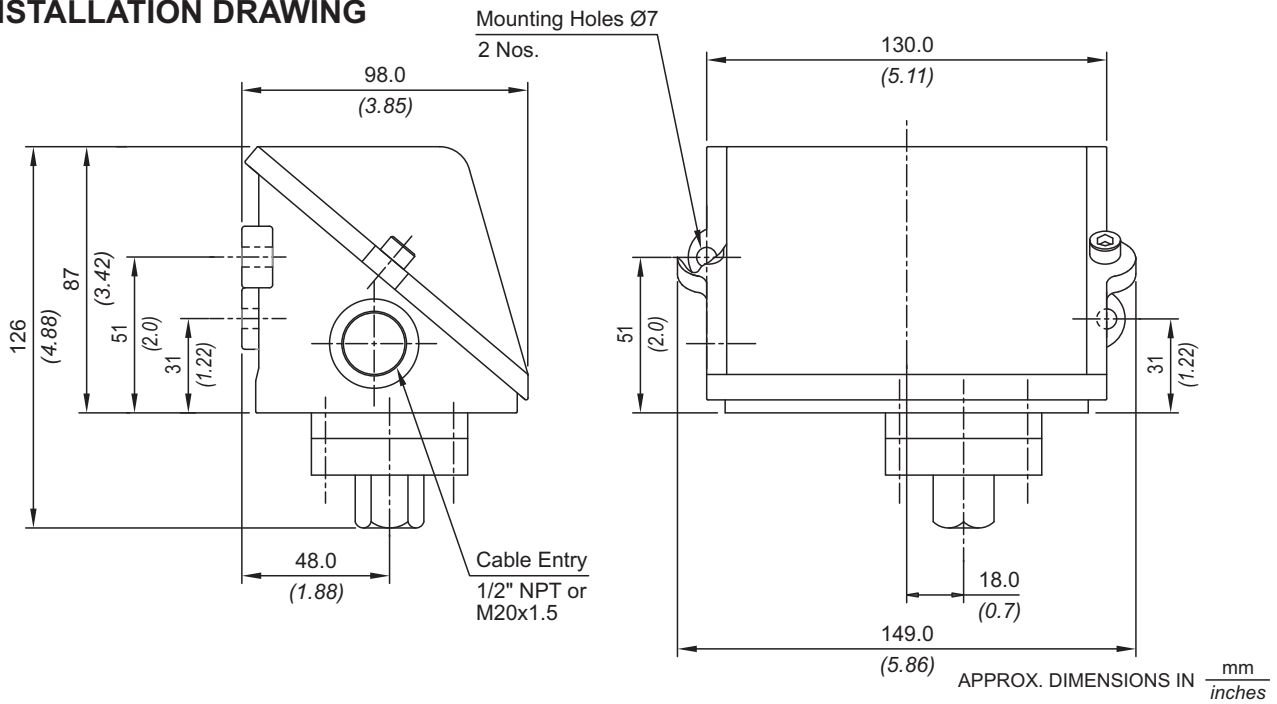

RANGE SELECTION TABLE

Range Code	Range bar (psi) ()	Differential* bar (psi)	Maximum Working Pressure bar (psi) ()
		Approximate Maximum for "A1" microswitch	
PP	0.067 - 0.213 (0.97 - 3.09)	0.04 (0.58)	70 (1015.27)
PP5	0.1 - 0.5 (1.45 - 7.25)	0.15 (2.176)	70 (1015.27)
P01	0.1 - 1.0 (1.45 - 14.50)	0.20 (2.90)	70 (1015.27)
P02	0.1 - 1.5 (1.45 - 21.76)	0.20 (2.90)	70 (1015.27)
P03	0.2 - 2.6 (2.90 - 37.71)	0.30 (4.35)	70 (1015.27)
P04	0.2 - 3.6 (2.90 - 52.21)	0.40 (5.80)	70 (1015.27)
P07	0.5 - 7.0 (7.25 - 101.50)	0.60 (8.70)	70 (1015.27)
P10	0.5 - 10.0 (7.25 - 145.04)	0.80 (11.60)	70 (1015.27)
P15	1.0 - 15.0 (14.5 - 217.6)	1.50 (23.21)	70 (1015.27)
P30	5.0 - 25.0 (72.52 - 362.5)	2.00 (29.00)	70 (1015.27)

*Minimum differential increases with setpoint, values with neoprene diaphragm (Graphs available on request)

*** Note :**

Microswitches A2 through A9 can be supplied in some ranges and differentials will vary with microswitch used. Please contact sales office for details. Please check availability of adjustable differential with sales office.

HOW TO ORDER INDUSTRIAL HIGH PROOF HIGH RANGE PRESSURE SWITCHES

Group 1	Group 2	Group 3	Group 4	Group 5	Group 6	Group 7	Group 8
Non standard allocation	Model	Cable Entry Size	Switch Type	Range Code (values in bar)	Microswitch Type	Pressure Port Material / Size	Diaphragm
<input type="checkbox"/> Reserved for non-standard options not covered in catalogue. Will be given by manufacturer, only after agreement of supply details with customer.	MT = Industrial pressure switch with diecast Aluminium enclosure to IP66 as per IS2147	1 = 1/2" NPT threads 3 = M20 X 1.5 threads	PF2 = pressure switch, fixed differential with scale in bar PF3 = pressure switch, fixed differential with scale in psi *PA2 = pressure switch, adjustable differential with scale in bar *PA3 = pressure switch, adjustable differential with scale in psi *Available with A9 (in group 6) only	PP = (0.067 - 0.213) PP5 = (0.1 - 0.5) P01 = (0.1 - 1.0) P02 = (0.1 - 1.5) P03 = (0.2 - 2.6) P04 = (0.2 - 3.6) P07 = (0.5 - 7.0) P10 = (0.5 - 10.0) P15 = (1.0 - 15.0) P30 = (5.0 - 25.0)	A1 = General purpose microswitch rated at 15 A; 250 VAC *A2 = Hermetically sealed for corrosive environments *A3 = gold plated contacts for low voltage applications *A4 = DPDT configuration *A5 = for high DC ratings *A7 = 2SPDT switching elements *A9 = General purpose microswitch rated at 5 A; 250 VAC * Please refer note under Range Selection Table	S1 = SS316 / 1/4" BSP(F) S2 = SS316 / 1/4" NPT(F)	0 = Neoprene 1 = Teflon 2 = SS 316L

eg. A high proof high range weatherproof switch with 1/2" NPT cable entry in aluminium housing as 1SPDT pressure switch, fixed differential without scale, having 0.1 bar to 1 bar pressure range, with 15 Amp. microswitch, SS316 pressure housing with 1/4" BSP port size & neoprene diaphragm shall be specified by

Group 1	Group 2	Group 3	Group 4	Group 5	Group 6	Group 7	Group 8
<input type="checkbox"/>	MT	1	PF2	P01	A1	S1	0

Please specify full model number to avoid ambiguity.