

LOW RANGE PRESSURE DIFFERENCE SWITCHES

FC/FE



FE



PRESSURE CAPSULE DETAILS

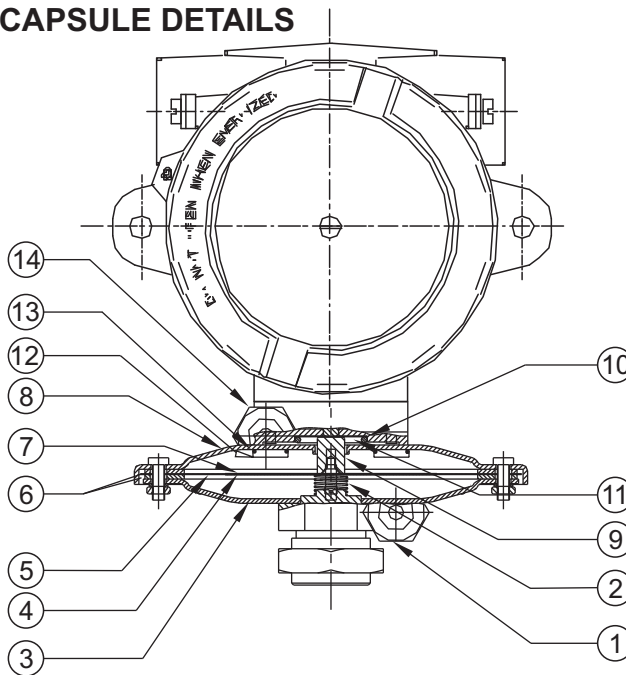

No. Description

1. High pressure port (S.S.)*
2. Support spring (S.S.)
3. Bottom flange (S.S.)
4. Support plate (Aluminium)
5. Diaphragm (Neoprene)
6. Gasket (Nitrile)
7. Top plate (Aluminium)
8. Top flange (M.S.)*
9. Transfer pin (Aluminium)
10. 'O' ring (Nitrile)
11. Sealing diaphragm (Nitrile)
12. Top flange screw (M.S.)
13. Sealing 'O' ring (Nitrile)
14. Low pressure port (M.S.)*

* Pressure ports are brazed with flange

Note : *wetted parts* are mentioned in italics.

INSTALLATION DRAWING

