

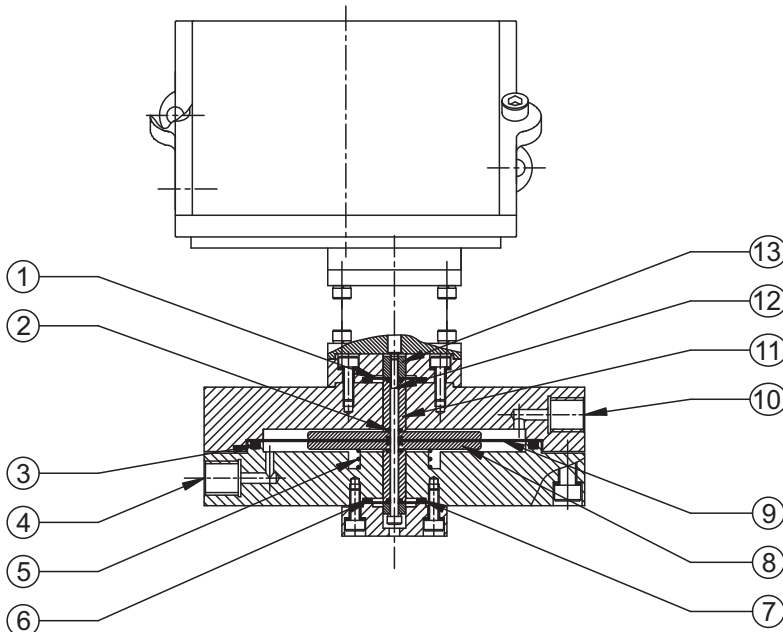

PRESSURE CAPSULE DETAILS



No. Description

1. Sealing diaphragm (Neoprene)
2. 'O' Ring (Viton)
3. 'O' Ring (Teflon)
4. High Pr. flange (S.S.)
5. Support spring (S.S.)
6. Support ring (S.S.)
7. Sealing ring (Teflon)
8. Support plate (S.S.)
9. Diaphragm (Neoprene)
10. Low Pr. flange (S.S.)
11. Transfer pin (S.S.)
12. Clamping screw (C.S.)
13. Lock nut (S.S.)

Note : wetted parts are mentioned in italics.

INSTALLATION DRAWING

