

PRESSURE CAPSULE DETAILS

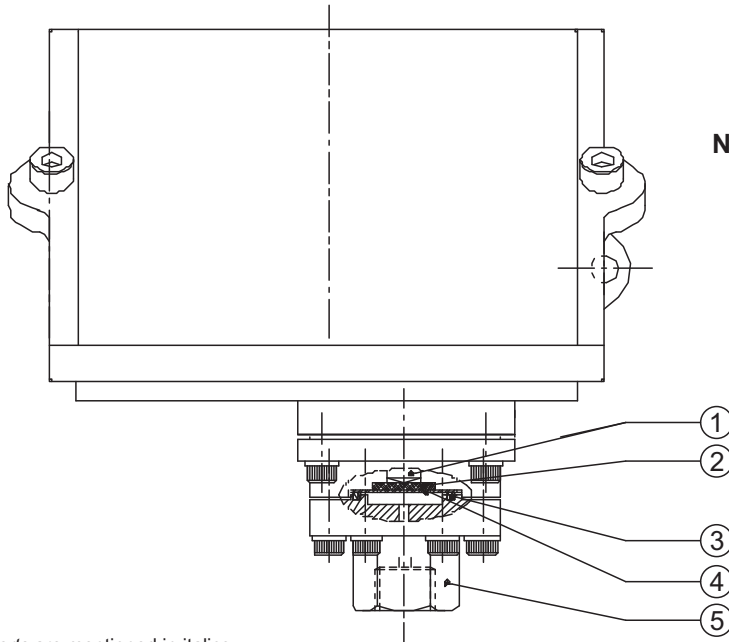

No. Description

1. Transfer Pin
2. Cushioning Pad
3. Teflon 'O' ring
4. Diaphragm
5. Pressure Housing

Note : *wetted parts* are mentioned in italics.

*Pressure ports are brazed with flange

INSTALLATION DRAWING

