

SE SUBMINIATURE SWITCHES



General information:

SE series subminiature pressure switches are low cost options. They are generally used where size is a constraint. Typical applications are to sense oil pressure in power packs. Can also be used for several automation applications.

Features:

- Compact
- Lightweight (Approx. 0.11 Kg.)
- Normally closed (NC) or normally open (NO) or SPDT
- Electrical rating: 5A, 250VAC; 0.2A, 250 VDC (res.)
- Switching point easy to adjust
- Material : Body - Aluminium; Pressure housing - Brass/MS/SS
- Wetted parts : MS/Brass/SS316L, Neoprene, Teflon
- Pressure port : 1/4" BSP(M), other sizes available

Range Selection Table

Range Code	Range bar (psi)	Differential* bar (psi) (Approx. Maximum)	Maximum Working Pressure bar (psi)
H01	0.2 - 1.0 (2.90 - 14.50)	0.2 (2.90)	35 (507.5)
H04	0.2 - 3.6 (2.9 - 52.20)	0.4 (5.8)	35 (507.5)
H10	0.5 - 10.0 (7.14 - 142.86)	1.0 (14.50)	35 (507.5)
H30	2.0 - 25.0 (29.00 - 362.6)	2.0 (29.00)	35 (507.5)

*Differential increases with set point, graph available on request.

Other model with range upto 200 bar available. Please contact sales office.

How to order SE Series Subminiature Switches

Group 1	Group 2	Group 3	Group 4	Group 5	Group 6	Group 7	Group 8
Non Standard Allocation	Model	Terminal Type	Switch Type	Range Code	Operating Type	Pressure Port Material / Size	Diaphragm
<input type="checkbox"/> Reserved for non-standard options not mentioned in catalogue. Will be given by manufacturer, only after agreement of supply details with customer.	SE = Subminiature Type	1 = Plug Type	PFO = Pressure Switch Fixed Differential	H01 = (0.2 - 1.0) H04 = (0.2 - 3.6) H10 = (0.5 - 10.0) H30 = (2.0 - 25.0)	A1 = With Silver Contact NC A2 = With Silver Contact NO A3 = With Silver Contact SPDT	M3 = Mild Steel / 1/4" BSPM S3 = SS316L / 1/4" BSPM B3 = Brass / 1/4" BSPM S6 = SS316L / M10x1 M	0 = Neoprene 1 = Teflon 2 = SS316L

e.g.: A single subminiature switch, high pressure range from 0.1 - 1.0 bar in uncalibrated style with mild steel pressure port & a neoprene diaphragm shall be specified by

Group 1	Group 2	Group 3	Group 4	Group 5	Group 6	Group 7	Group 8
<input type="checkbox"/>	SE	1	PFO	H01	A1	M3	0

Please specify full model number to avoid ambiguity. If only the first two groups are specified while ordering, switches with standard wetted parts will be supplied.

Construction :

The pressure switch is housed in a rolled aluminium enclosure. The pressure capsule, at the bottom of the switch, comprises a pressure housing (Brass/MS/SS), a disc, a diaphragm (Neoprene, Teflon) and a plunger. This is a plug type switch with NO (Normally Open) or NC (Normally Closed) or SPDT contacts. The electrical terminations are standard Push On type. Figure 1.

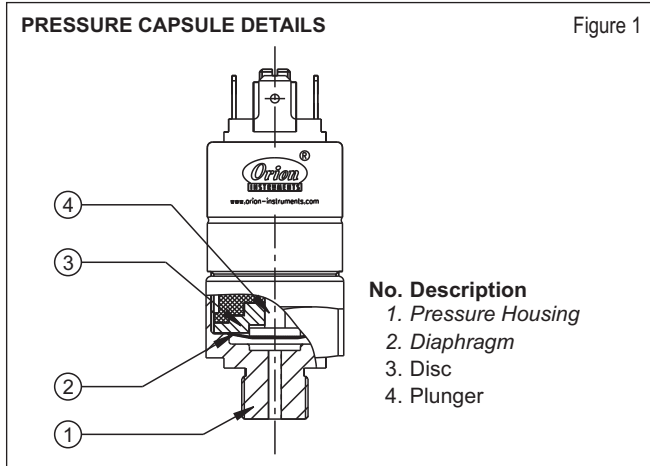

Principle of Operation :

The pressure in the pressure capsule is converted into force by means of a diaphragm and a calibrated piston, which is balanced by a compression spring from above. When the force generated by the pressure in the pressure capsule exceeds/falls beyond the balancing spring force, an electrical element is actuated/deactuated.

Mounting :

- 1) The SE series subminiature switches have stem type mounting and can be mounted in any direction.
- 2) The pressure port size is generally 1/4" BSP(M), unless specifically ordered otherwise. Other sizes can be obtained via adaptors for small quantities. For larger quantities, customized thread ends can be provided.

CAUTION : Tightening torque should not exceed by 4kg-m.

Electrical Connections :

These pressure switches will generally have NO (Normally Open) or NC (Normally Closed) or SPDT contact terminals. Figure 3.

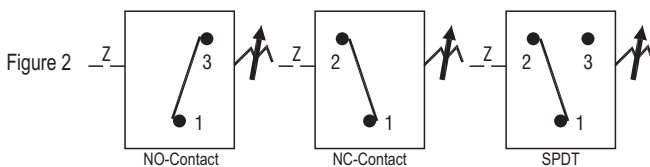

Caution : Please isolate electrical supply before wiring. Use rubber insulation cap provided whenever wires are live. (Not doing so will be fatal)

Wiring :

Connect the wires to the contact terminals as per your wiring diagram.

Set Point Adjustment :

- 1) The switching point can be easily adjusted by turning the setting screw located in between the contacts. Figure 3.
- 2) Apply the desired cutin (lower) / cutout (higher) pressure to the pressure switch.
- 3) Increase the pressure setting by turning the setting screw till contacts changeover.
- 4) Some minor adjustment will be required to achieve the exact cutin (lower) / cutout (higher) point, which can be checked with the help of a proper pressure measurement device and a multimeter.

Tip : The pressure switches are factory set at half the set point range (unless otherwise specified in a Purchase Order).

Trouble Shooting Tips

Generally no problems are observed if the pressure switch selection, wiring and the setpoint is proper. For a pressure switch selection procedure please consult our sales office.

For properly selected pressure switches, if following symptoms are observed, the likely causes and remedies are as stated below:

Symptom 1: Switch does not operate

- 1) Wiring may not be correct. Check electric connections to the pressure switch, if they are as per the wiring diagram.
- 2) Pressure does not reach the pressure port.

INSTALLATION DRAWING

Figure 3

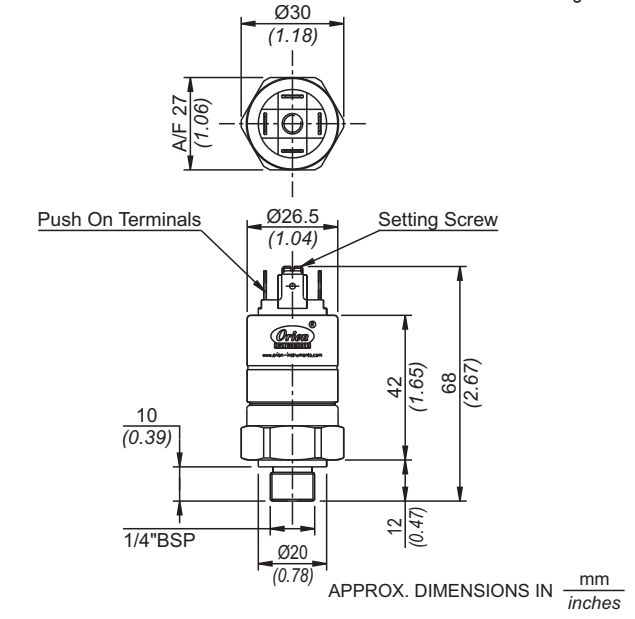

- a) Check if the entry to the pressure capsule is not blocked by frozen process or scales or impurities in the process.
 - i) If this is the case, try freeing the blocked path by a blunt tool in case of scales or impurities in the process.

DO NOT OPEN THE PRESSURE CAPSULE IN ANY EVENT

If the cause is none of the above mentioned probabilities, proceed as per the following steps.

- b) Check the system pressure and set point of pressure switch. For use of pressure switch for falling setpoints, system pressure has to be greater than cutin point. For use of pressure switch for rising setpoints, the system pressure may not be reaching or exceeding the cutout point.
 - i) Use 'T' connection and connect calibrated pressure gauge to the 'T' connection as shown in Figure 4.
 - ii) Adjust the setpoint such that the system pressure is greater than the cut-out point of the pressure switch.

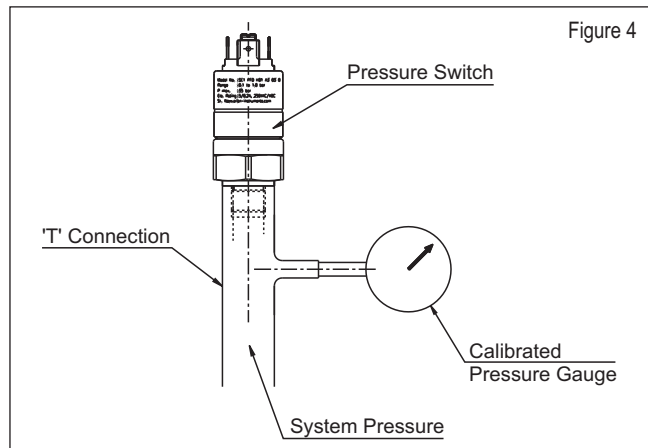

Symptom 2: Leakage

In case leakage is observed, the pressure switch has to be returned to the factory without opening the pressure capsule. Check for the following likely causes and use a new switch taking proper precautions.

- a) System pressure is greater than working pressure : Use an overrange protector or a switch with greater maximum working pressure.
- b) Incompatible wetted parts : The working medium may not be compatible with wetted parts, which damages the sealing of the process from working parts. Please choose proper compatible wetted parts.
- c) Excessive process temperature : Process temperature may exceed maximum allowable temperature, which in turn damages the diaphragms. Use an impulse tube to cool down process temperature.