

MZ HIGH RANGE PRESSURE SWITCHES

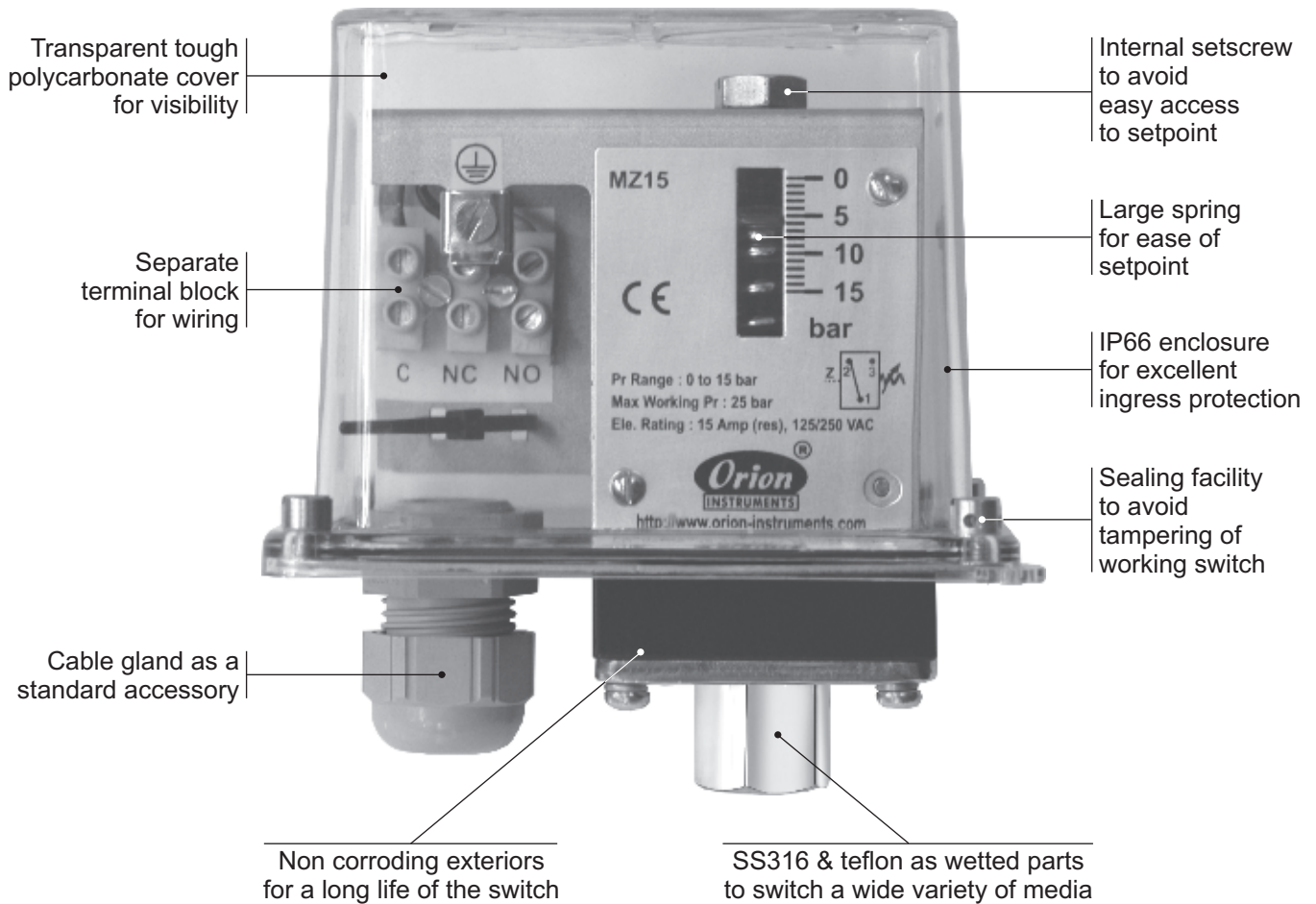

Approximate Weight : 0.550 Kg.

Some Applications :

Used in humid or slightly corrosive atmosphere like jet dyeing machines, etc.

Electrical Connection :

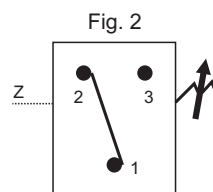



PRESSURE CAPSULE DETAILS

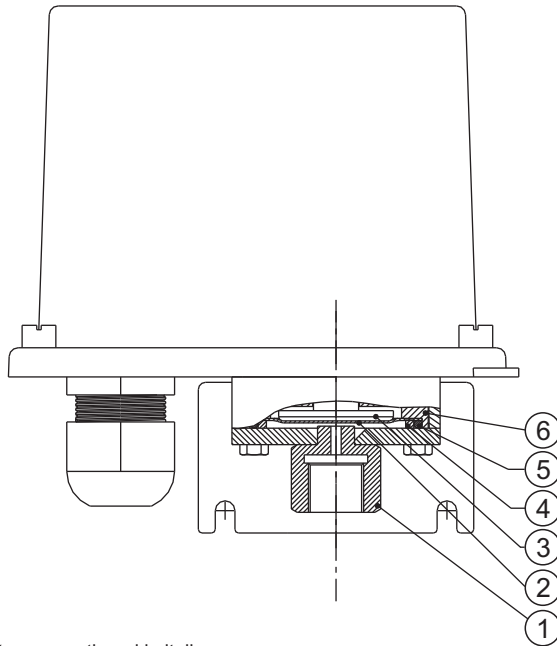

No. Description

1. Pressure Housing (SS316)
2. Diaphragm (Teflon[®])
3. Plunger
4. Steel Ring (SS316)
5. O-Ring (Teflon[®])
6. Disc

Note : *wetted parts* are mentioned in italics.

INSTALLATION DRAWING

Cover Locking Screw
4 Nos.

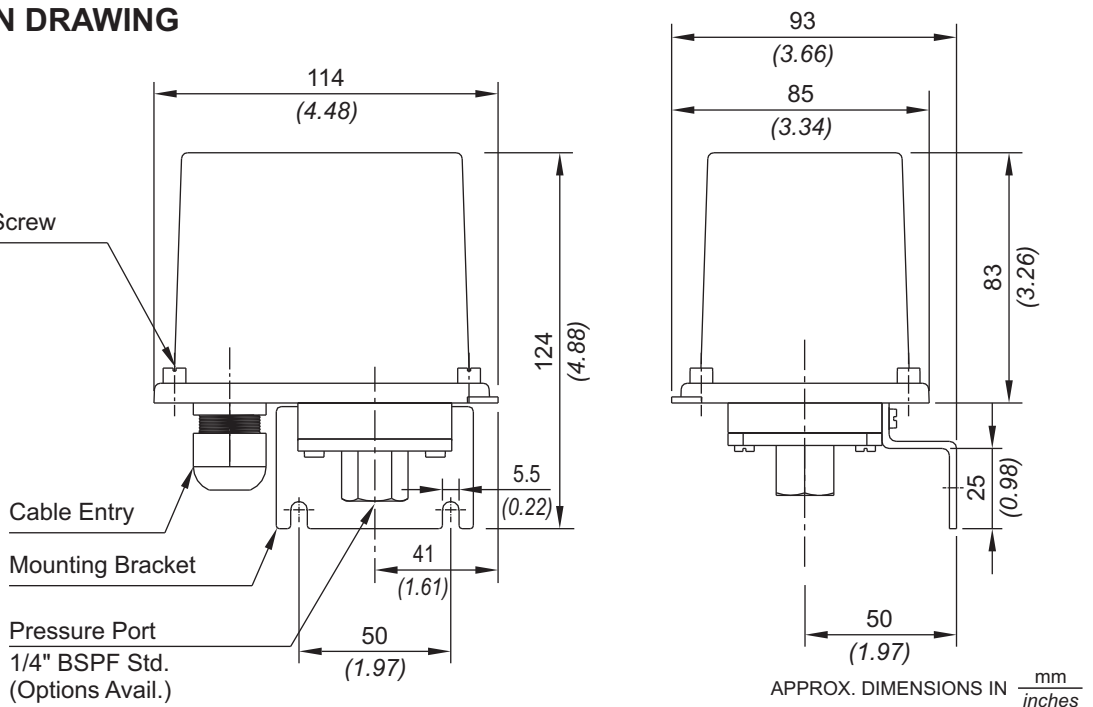

MZ HIGH RANGE PRESSURE SWITCHES

RANGE SELECTION TABLE

Range Code	Range bar (psi)	Differential* bar (psi)	Maximum Working Pressure bar (psi)
		Approximate Maximum for "A8" microswitch	
LP†	0.067 - 0.213 (0.97 - 3.09)	0.05 (0.72)	5 (72.52)
LP5	0.1 - 0.5 (1.45 - 7.25)	0.10 (1.45)	5 (72.52)
H01	0.1 - 1.0 (1.45 - 14.50)	0.10 (1.45)	12 (174.05)
H02	0.1 - 1.5 (1.45 - 21.76)	0.20 (2.90)	12 (174.05)
H03	0.2 - 2.6 (2.90 - 37.71)	0.20 (2.90)	12 (174.05)
H04	0.2 - 3.6 (2.90 - 52.21)	0.20 (2.90)	12 (174.05)
H07	0.5 - 7.0 (7.25 - 101.50)	0.40 (5.80)	12 (174.05)
H10	0.5 - 10.0 (7.25 - 145.04)	0.60 (8.70)	25 (362.6)
H15	1.0 - 15.0 (14.50 - 217.56)	0.60 (8.70)	25 (362.6)
H30	5.0 - 25.0 (72.52 - 362.6)	0.80 (11.60)	35 (507.63)

*Minimum differential increases with setpoint (Graphs available on request), results for neoprene diaphragm.

†Range not available in SS316 L diaphragm.

HOW TO ORDER PROCESS HIGH RANGE PRESSURE SWITCHES

Group 1	Group 2	Group 3	Group 4	Group 5	Group 6	Group 7	Group 8
Non standard allocation	Model	Cable Entry Size	Switch Type	Range Code (values in bar)	Microswitch Type	Pressure Port Material / Size	Diaphragm
<input type="checkbox"/> Reserved for non-standard options not covered in catalogue. Will be given by manufacturer, only after agreement of supply details with customer.	MZ = Process pressure switch with tough transparent polycarbonate enclosure to IP66 as per IS2147	3 = M20 X 1.5 cable gland	PF2 = pressure switch, fixed differential with scale in bar PF3 = pressure switch, fixed differential with scale in psi *PA2 = pressure switch, adjustable differential with scale in bar *PA3 = pressure switch, adjustable differential with scale in psi <small>*Available only with option A9 in Group 6</small>	LP = (0.067 - 0.213) LP5 = (0.1 - 0.5) H01 = (0.1 - 1.0) H02 = (0.1 - 1.5) H03 = (0.2 - 2.6) H04 = (0.2 - 3.6) H07 = (0.5 - 7.0) H10 = (0.5 - 10.0) H15 = (1.0 - 15.0) H30 = (5.0 - 25.0)	A8 = General purpose microswitch rated at 5A; 250 VAC A7 = 2SPDT microswitches A9 = General purpose microswitch rated @ 5A, 250 VAC <small>* Please refer note under Range Selection Table</small>	S1 = SS316 / 1/4" BSP(F) S2 = SS316 / 1/4" NPT(F) <small>Please refer page no. 226 & 227 for more pressure port options</small>	0 = Neoprene 1 = Teflon 2 = SS 316L 4 = Monel

eg. A process pressure switch with fixed differential having 0.1 bar to 1 bar pressure range, with 5 Amp. microswitch, SS316 pressure housing with 1/4" BSP port size & neoprene diaphragm shall be specified by

Group 1	Group 2	Group 3	Group 4	Group 5	Group 6	Group 7	Group 8
<input type="checkbox"/>	MZ	3	PF2	H01	A8	S1	0

Please specify full model number to avoid ambiguity.