

# MZ HYDRAULIC RANGE PRESSURE SWITCHES

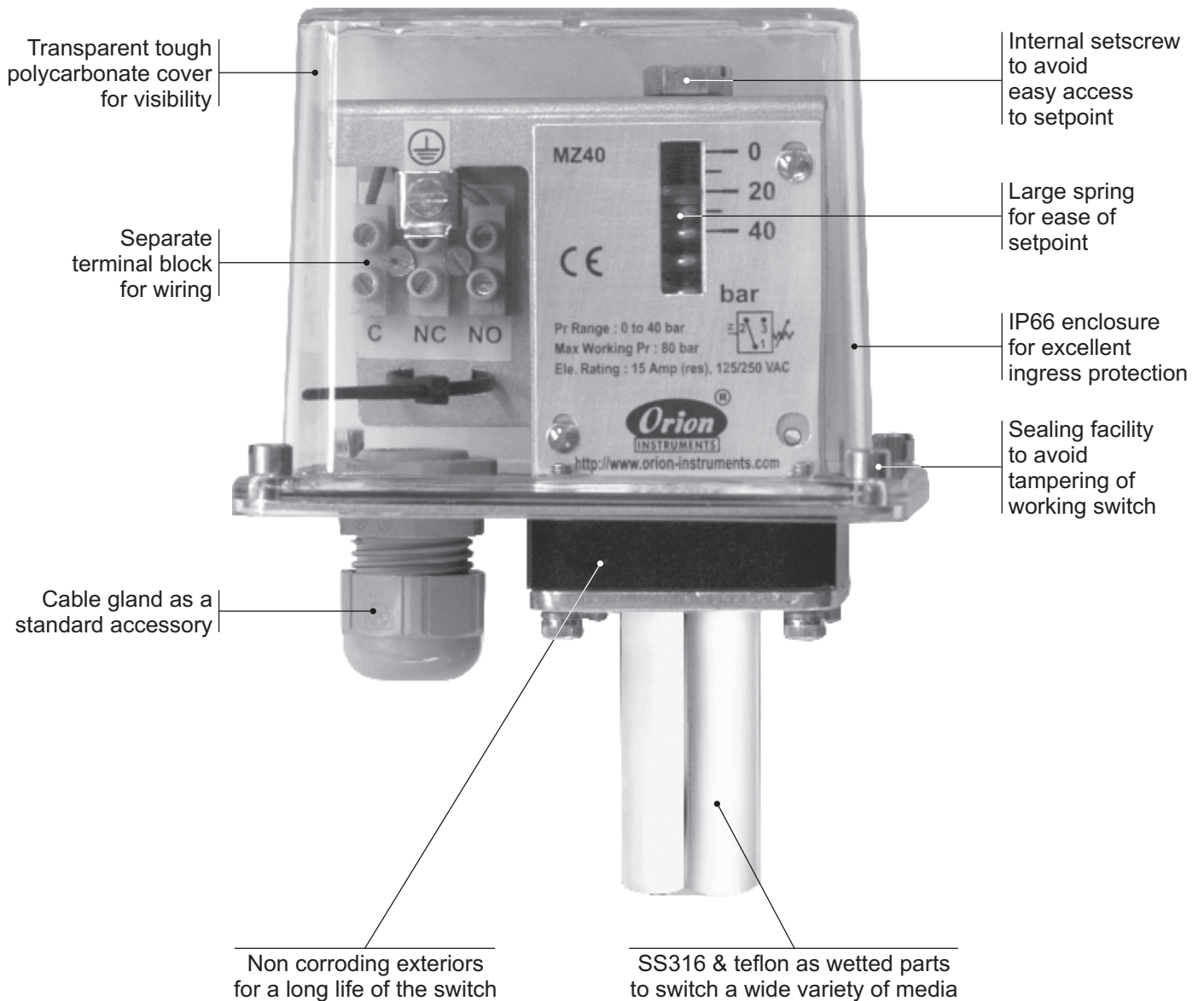

**Approximate Weight :** 0.680 Kg.

**Some Applications :**

Used where pressure surges and fluctuations may be present like oil hydraulic systems, etc.

**Electrical Connection :**

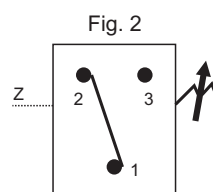



## PRESSURE CAPSULE DETAILS

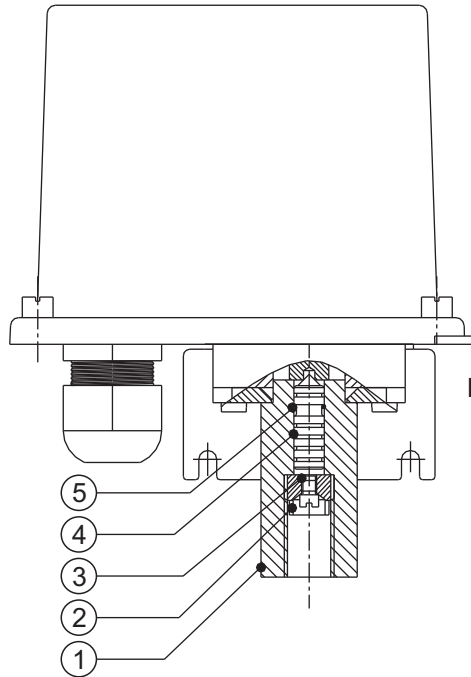

### No. Description

1. Pressure housing (SS)
2. Surge Arrestor (SS)
3. Surge Reducer (SS)
4. Piston (SS)
5. O-Ring (Viton®)

Note : *wetted parts* are mentioned in italics.

## INSTALLATION DRAWING

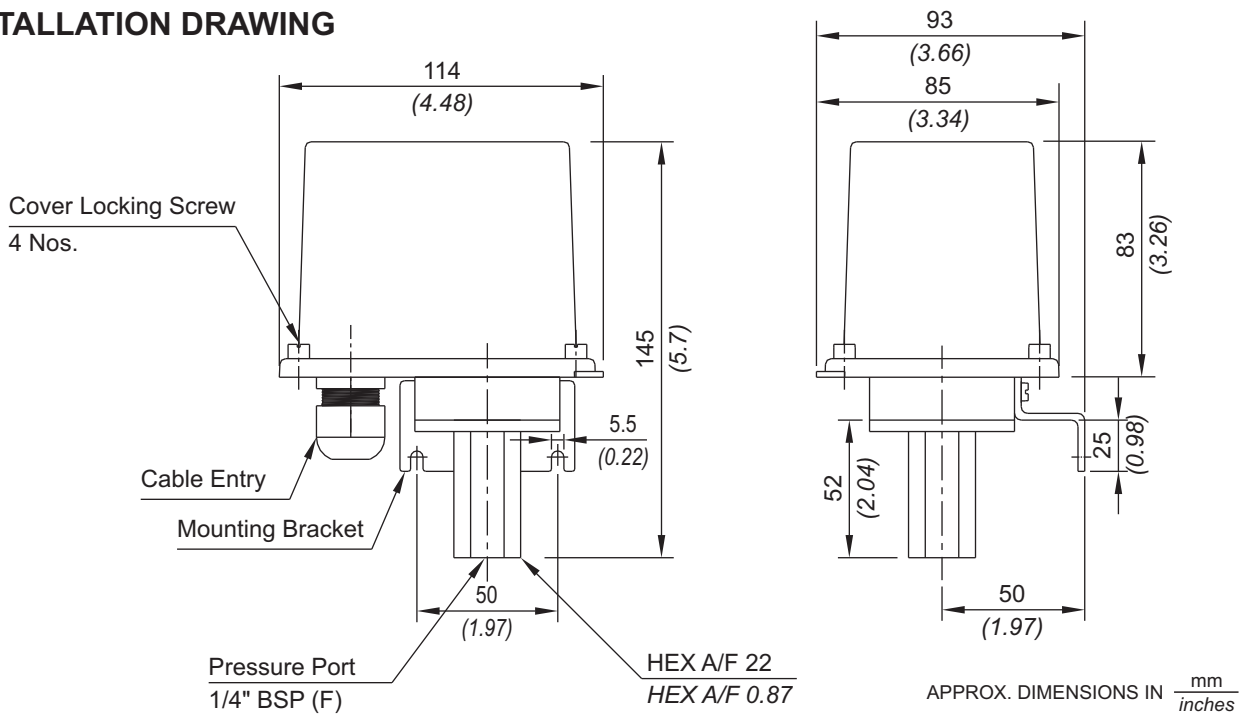

# MZ HYDRAULIC RANGE PRESSURE SWITCHES

## RANGE SELECTION TABLE

Range Code	Range bar (psi)	Differential* bar (psi)	Maximum Working Pressure bar (psi)
		Approximate Maximum for "A8" microswitch	
040	5 - 40 (72.52 - 580.15)	5 (72.52)	80 (1160.31)
100	10 - 100 (145.04 - 1450.38)	12 (174.05)	120 (1740.45)
200	7 - 200 (101.63 - 2900.75)	24 (348.09)	200 (2900.75)
350	35 - 350 (101.53 - 2900.75)	24 (348.09)	500 (7251.89)
400	100 - 400 (1450.38 - 5801.51)	30 (435.11)	400 (5801.59)

\*Minimum differential increases with setpoint (Graphs available on request)

## HOW TO ORDER PROCESS HYDRAULIC RANGE PRESSURE SWITCHES

# HYDRAULIC RANGE PRESSURE SWITCHES

# MZ

Group 1	Group 2	Group 3	Group 4	Group 5	Group 6	Group 7	Group 8
Non standard allocation	Model	Cable Entry Size and Material of Enclosure	Switch Type	Range Code (values in bar)	Microswitch Type	Pressure Port Material / Size	Piston
<input type="checkbox"/> Reserved for non-standard options not covered in catalogue. Will be given by manufacturer, only after agreement of supply details with customer.	<b>MZ</b> = Process pressure switch with tough transparent polycarbonate enclosure to IP66 as per IS2147	<b>3</b> = M20 X 1.5 cable gland	<b>PF2</b> = pressure switch, fixed differential with scale in bar <b>PF3</b> = pressure switch, fixed differential with scale in psi <b>*PA2</b> = pressure switch, adjustable differential with scale in bar <b>*PA3</b> = pressure switch, adjustable differential with scale in psi *Available only with option A9 in Group 6	<b>040</b> = (5 - 40) <b>100</b> = (10 - 100) <b>200</b> = (7 - 200) <b>350</b> = (35 - 350) <b>400</b> = (100 - 400)	<b>A8</b> = General purpose microswitch rated at 5A; 250 VAC <b>A7</b> = 2SPDT microswitches <b>A9</b> = General purpose microswitch rated @ 5A, 250 VAC	<b>S1</b> = SS316 / 1/4" BSP(F) <b>S2</b> = SS316 / 1/4" NPT(F)	<b>2</b> = SS
					* Please refer note under Range Selection Table	Please refer page no. 226 & 227 for more pressure port options	

eg. A process pressure switch with fixed differential having 5 bar to 40 bar pressure range, with 5 Amp. microswitch, SS316 pressure housing with 1/4" BSP port size & neoprene diaphragm shall be specified by

Group 1	Group 2	Group 3	Group 4	Group 5	Group 6	Group 7	Group 8
<input type="checkbox"/>	MZ	3	PF2	040	A8	S1	0

Please specify full model number to avoid ambiguity.